

# Compact READY Benders®

• Designed to fit "tight" die spaces, small footprint.

- Recommended for high production applications.
- Hardened tool steel, all surfaces precision ground. Rockers Rc 56-62. Saddles Rc 48-52. Chase or Yoke mounting by die maker.
- Standards in stock for fast delivery. Special compact benders can be made to your height and length requirements upon request.

The original compact benders called CBT and CLT are not discontinued. See earlier catalog or request a fax sheet to detail the parameters.

## Selection and Ordering:

1. Locate the material thickness you are forming on the top row. Read down the column for your data.
2. Longer lengths are achieved by butting units end-to-end.
3. We make special compact benders. Fax the worksheet on the back cover with prints.

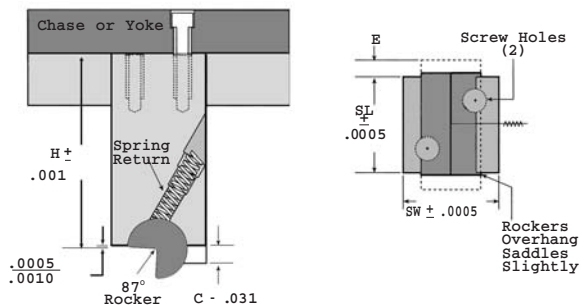

### Regular Benders

Note: extended rockers (E) are special

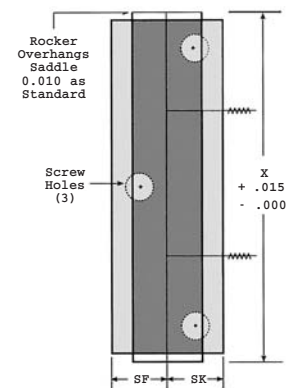

For All HiPRO Compacts SF and SK Equal 1/2 SW  
 \*\*\* = Spring Return

### Long Benders

Ends of saddles are not ground

PART MATERIAL		PART MATERIAL THICKNESS RANGES (inches)			
Mild Steel		.010" - .042"	.043" - .075"	.076" - .120"	.121" - .165"
REGULAR BENDERS		STANDARD			
Catalog Callout (stocked)		HCBT 62	HCBT 100	HCBT 150	HCBT 200
		Bender Dimensions			
Rocker Diameter	D	.625	1.000	1.500	2.000
Regular Benders	SW x SL	1.000" x 1.000"	1.500" x 1.500"	2.000" x 2.000"	3.000" x 3.000"
Height	H	2.000"	2.000"	2.750"	3.000"
Rocker Extension (special)	E	1/4"	1/4"	3/8"	1/2"
LONG BENDERS		SPECIAL ORDER			
Catalog Callout (special)		HCLT 62	HCLT 100	HCLT 150	HCLT 200
Long Benders, width	SW	1.000"	1.500"	2.000"	3.000"
Length (specify)	X	1.500" - 6.000"	2.000" - 8.000"	2.750" - 8.000"	3.000" - 8.000"
Height (specify)	H	2.000" - 3.000"	2.000" - 3.000"	2.750" - 3.750"	3.000" - 4.000"
Rocker Dimensions		Designer Dimensions (87° Rocker)			
	B	.212"	.339"	.508"	.678"
	C	.195"	.312"	.468"	.624"
	J	.246"	.393"	.590"	.786"
SHCS screws		1/4 - 20	5/16 - 18	5/16 - 18	1/2 - 13

## Take Advantage of the Latest Bender Technology

READY encourages upgrading to the improved designs detailed in this catalog for best performance, delivery, and lowest tooling costs. We now offer longer one piece full hard benders in lengths up to 36" long.

We make specials too ... use the worksheet on back cover and fax prints.