





READY DESIGN-TITE® LE Series International Organization for Standardization (ISO) Line Nitrogen Gas (N₂) Springs

Every ISO gas springs meets all ISO and VDI piston rod, body and height standards, In addition to mounting and charge port specifications. Body Diameter: 45mm to 195mm

Body Diameter: 45mm to 195mm
Open Force: 1050 lbs to 22,500 lbs
Closed Force: 1575 lbs to 31,500 lbs



MODEL	ØBody mm	Strokes mm	 Fo daN		 ACTIVE SAFETY			ISO STANDARD
LE-500	45	10 - 160	470	✓	✓	✓	✓	✓
LE-750	50	13 - 300	740	✓	✓	✓	✓	✓
LE-1500	75	13 - 300	1500	✓	✓	✓	✓	✓
LE-3000	95	25 - 300	3000	✓	✓	✓	✓	✓
LE-5000	120	25 - 300	5000	✓	✓	✓	✓	✓
LE-7500	150	25 - 300	7500	✓	✓	✓	✓	✓
LE-10000	195	25 - 200	10000	✓	✓	✓	✓	✓

LE-500

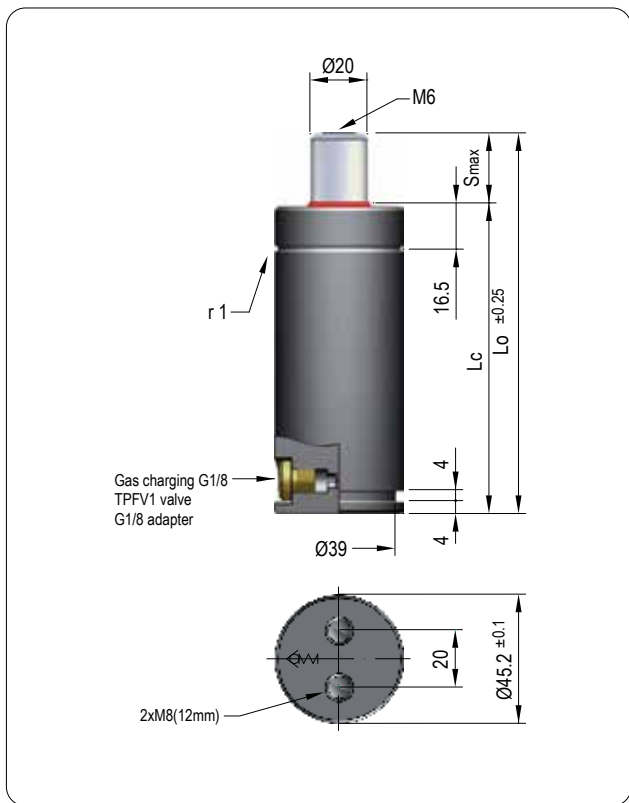

Pressure medium	Gas Nitrogen (N ₂)
Max. charging pressure	150 Bar
Min. charging pressure	35 Bar
Rod seal area	3,14 cm ²
Operating temperature	0°C - 80°C
Force increase by temperature	0,33 %/°C
Max. stem speed	1,6 m/s
Maintenance kit	Kit S500.2



Maximum strokes / minute (at 20°C)

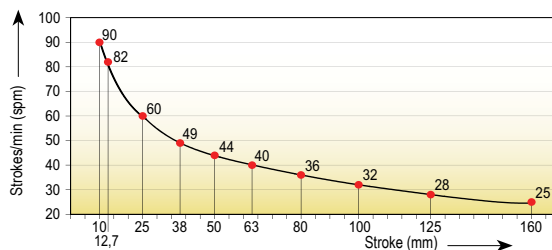

MODEL	S _{max} mm	L _o mm	L _c mm	F _o daN	90% F daN	100% F _c daN	P Bar	V l	Kg
LE-500x10	10	105	95	470 ±5% (20°C)	575	590	150 (20°C)	0,016	0,43
LE-500x13	12,7	110,4	97,7		580	595		0,019	0,44
LE-500x25	25	135	110		605	625		0,032	0,46
LE-500x38	38	161	123		615	635		0,046	0,51
LE-500x50	50	185	135		620	640		0,060	0,59
LE-500x63	63	212	149		620	645		0,074	0,66
LE-500x80	80	245	165		625	645		0,092	0,73
LE-500x100	100	285	185		625	650		0,114	0,83
LE-500x125	125	335	210		630	650		0,142	0,96
LE-500x160	160	405	245		715	760		0,133	1,05

Force/stroke ratio

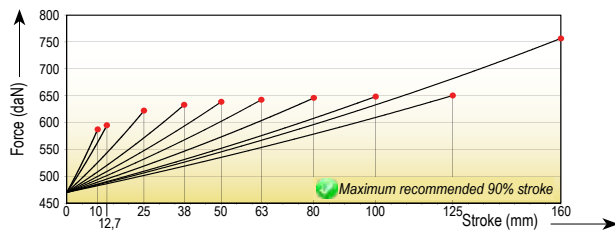

Initial force/charging pressure ratio

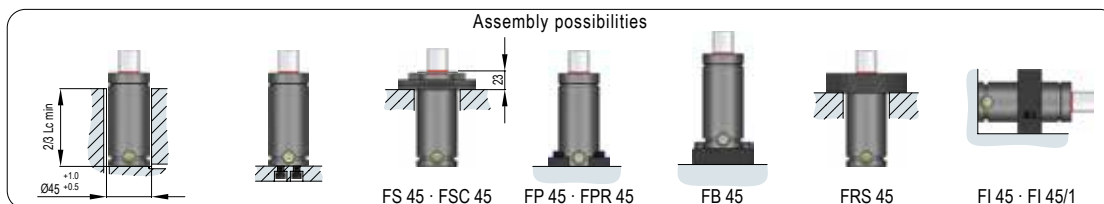
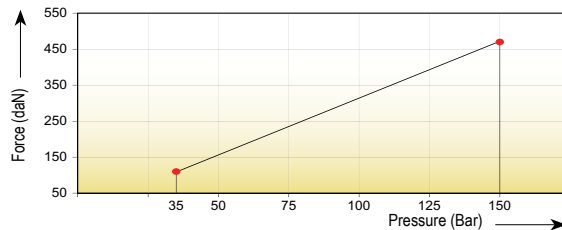

Product improvement through research and development is an ongoing process. All specifications are subject to change without notice.

LE-750

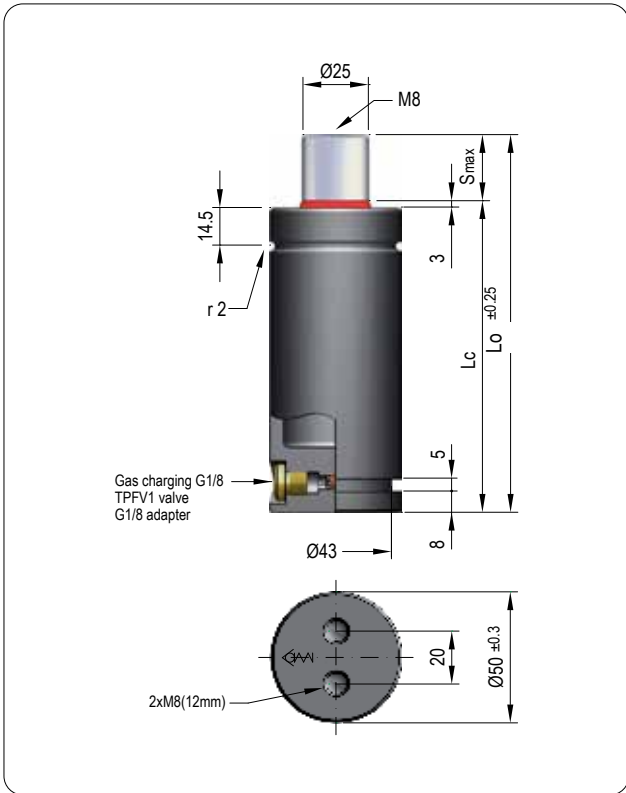

Pressure medium	Gas Nitrogen (N_2)
Max. charging pressure	150 Bar
Min. charging pressure	35 Bar
Rod seal area	4,91 cm ²
Operating temperature	0°C - 80°C
Force increase by temperature	0,33 %/°C
Max. stem speed	1,6 m/s
Maintenance kit	Kit S750



Maximum strokes / minute (at 20°C)

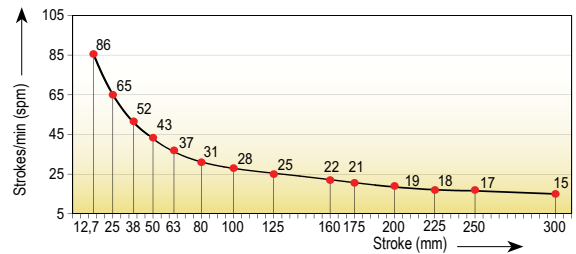

MODEL	S _{max} mm	L ₀ mm	L _c mm	F ₀ daN	90% F daN	100% F _c daN	P Bar	V l	Kg
LE-750x13	12,7	120,4	107,7	740 ±5% (20°C)	865	880	150 (20°C)	0,037	1,20
LE-750x25	25	145	120		930	960		0,053	1,35
LE-750x38	38	171	133		975	1010		0,069	1,40
LE-750x50	50	195	145		1000	1040		0,084	1,52
LE-750x63	63	222	159		1020	1065		0,101	1,70
LE-750x80	80	255	175		1035	1085		0,122	1,82
LE-750x100	100	295	195		1055	1105		0,147	1,85
LE-750x125	125	345	220		1065	1120		0,178	2,20
LE-750x160	160	415	255		1065	1120		0,229	2,30
LE-750x175	175	445	270		1070	1130		0,248	2,65
LE-750x200	200	495	295		1080	1135		0,279	3,10
LE-750x225	225	545	320		1085	1145		0,310	3,27
LE-750x250	250	595	345		1090	1150		0,342	3,60
LE-750x300	300	695	395		1095	1160		0,405	4,15

Force/stroke ratio

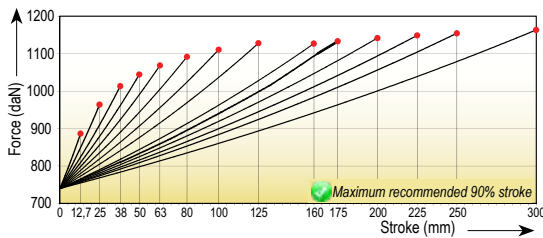

Initial force/charging pressure ratio

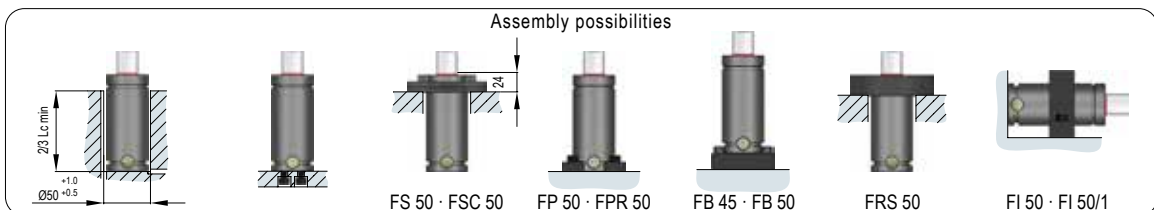
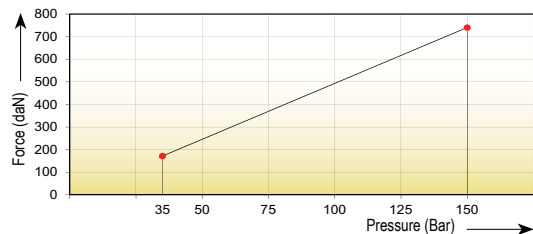

Product improvement through research and development is an ongoing process. All specifications are subject to change without notice.

LE-1500

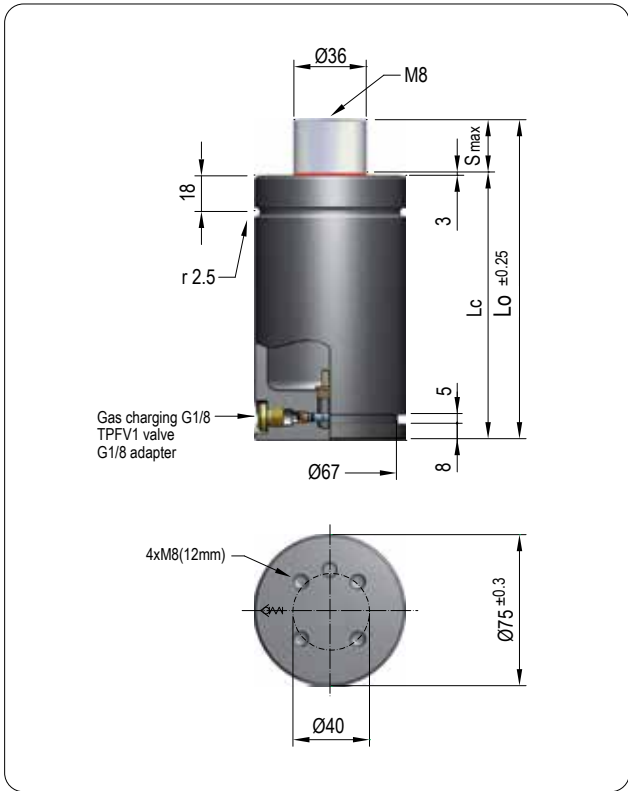

Pressure medium	Gas Nitrogen (N_2)
Max. charging pressure	150 Bar
Min. charging pressure	35 Bar
Rod seal area	10,18 cm^2
Operating temperature	0°C - 80°C
Force increase by temperature	0,33 %/°C
Max. stem speed	1,6 m/s
Maintenance kit	Kit S1500.1



Maximum strokes / minute (at 20°C)

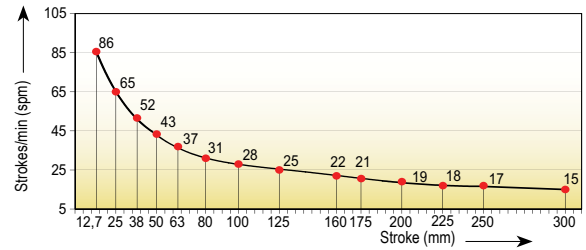

MODEL	S_{max} mm	L_o mm	L_c mm	F_o daN	90% F daN	100% F_c daN	P Bar	V l	Kg
LE-1500x13	12,7	135,4	122,7	1500 \pm 5% (20°C)	1665	1685	148 (20°C)	0,123	3,15
LE-1500x25	25	160	135		1745	1780		0,167	3,30
LE-1500x38	38	186	148		1800	1840		0,214	3,50
LE-1500x50	50	210	160		1835	1880		0,257	3,65
LE-1500x63	63	237	174		1860	1910		0,304	3,90
LE-1500x80	80	270	190		1885	1940		0,365	4,45
LE-1500x100	100	310	210		1905	1965		0,437	4,80
LE-1500x125	125	360	235		1925	1985		0,527	5,36
LE-1500x160	160	430	270		2090	2185		0,525	6,10
LE-1500x175	175	460	285		2050	2135		0,606	6,55
LE-1500x200	200	510	310		2060	2145		0,684	7,15
LE-1500x225	225	560	335		2065	2155		0,762	7,45
LE-1500x250	250	610	360		2070	2160		0,840	7,86
LE-1500x300	300	710	410		2080	2175		0,996	8,66

Force/stroke ratio

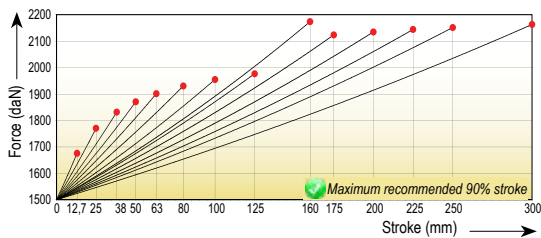

Initial force/charging pressure ratio

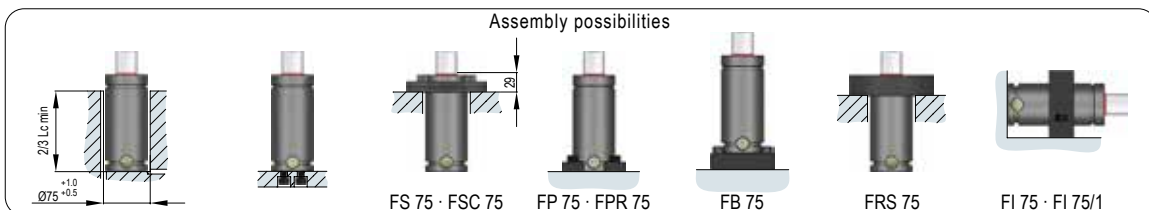
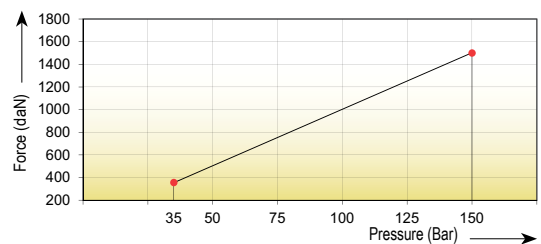

LE-10000

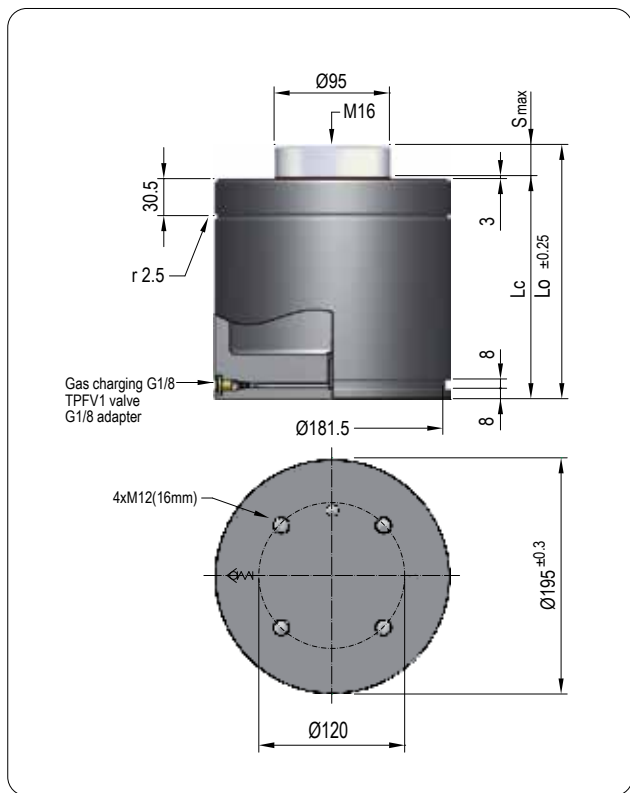

Pressure medium	Gas Nitrogen (N_2)
Max. charging pressure	150 Bar
Min. charging pressure	35 Bar
Rod seal area	70,88 cm^2
Operating temperature	0°C - 80°C
Force increase by temperature	0,33 %/°C
Max. stem speed	1,6 m/s
Maintenance kit	Kit S10000



Maximum strokes / minute (at 20°C)

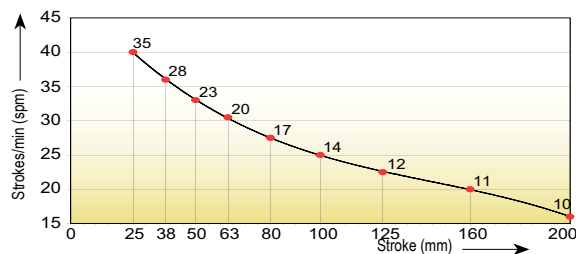

MODEL	S_{max} mm	L_o mm	L_c mm	F_o daN	90% F daN	100% F_c daN	P Bar	V l	Kg
LE-10000x25	25	210	185	10000 $\pm 5\%$ (20°C)	12310	12635	141 (20°C)	0,848	35,60
LE-10000x38	38	236	198		12690	13085		1,141	37,30
LE-10000x50	50	260	210		12910	13345		1,412	39,10
LE-10000x63	63	287	224		13075	13540		1,705	41,20
LE-10000x80	80	320	240		13225	13720		2,089	43,50
LE-10000x100	100	360	260		13345	13865		2,540	46,10
LE-10000x125	125	410	285		13450	13985		3,104	50,50
LE-10000x160	160	480	320		13545	14100		3,894	55,90
LE-10000x200	200	560	360		13615	14190		4,797	61,30

Force/stroke ratio

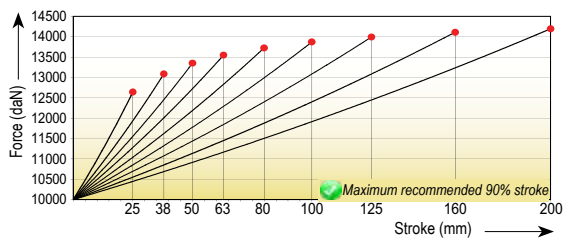

Initial force/charging pressure ratio

