

READY

THE INNOVATOR OF OUR INDUSTRY®

Standard and Custom Die Sets & Plates

Full Service and Full Range

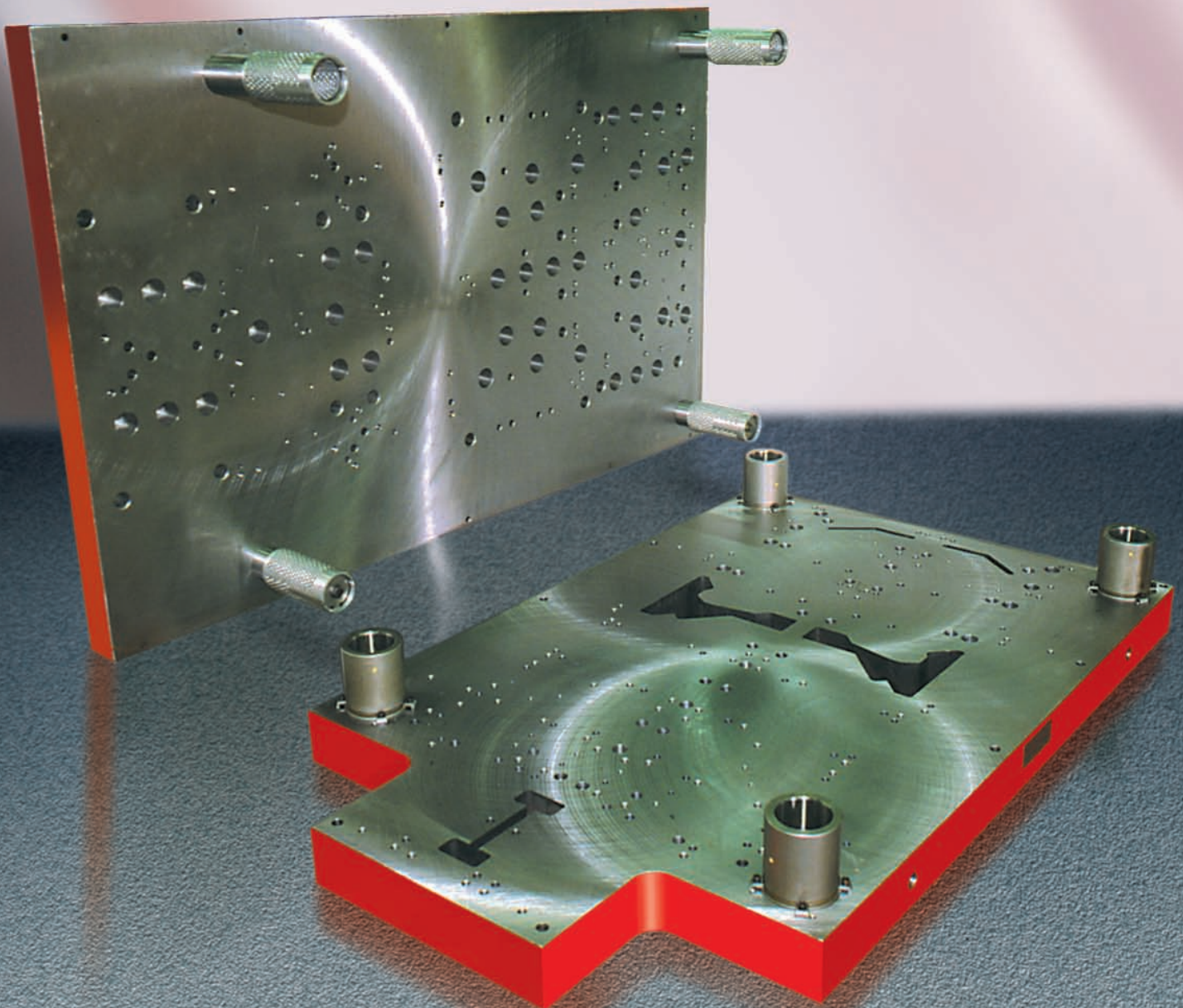

Protected by U.S. and International Patents

Die Sets - We offer a complete service

- "Next Day Die Set" - stock rectangular. "Order today, we'll ship tomorrow."
- Special Die Sets, both plain and ball bearing, and 3 Plate Die Sets.
- Aluminum Die Sets
- Blanchard Ground Plates, Special Machining, and Parallels.

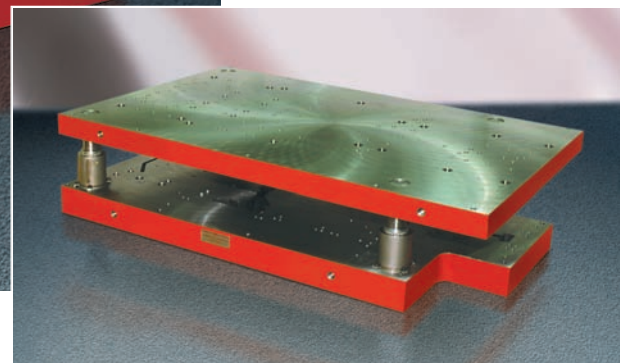
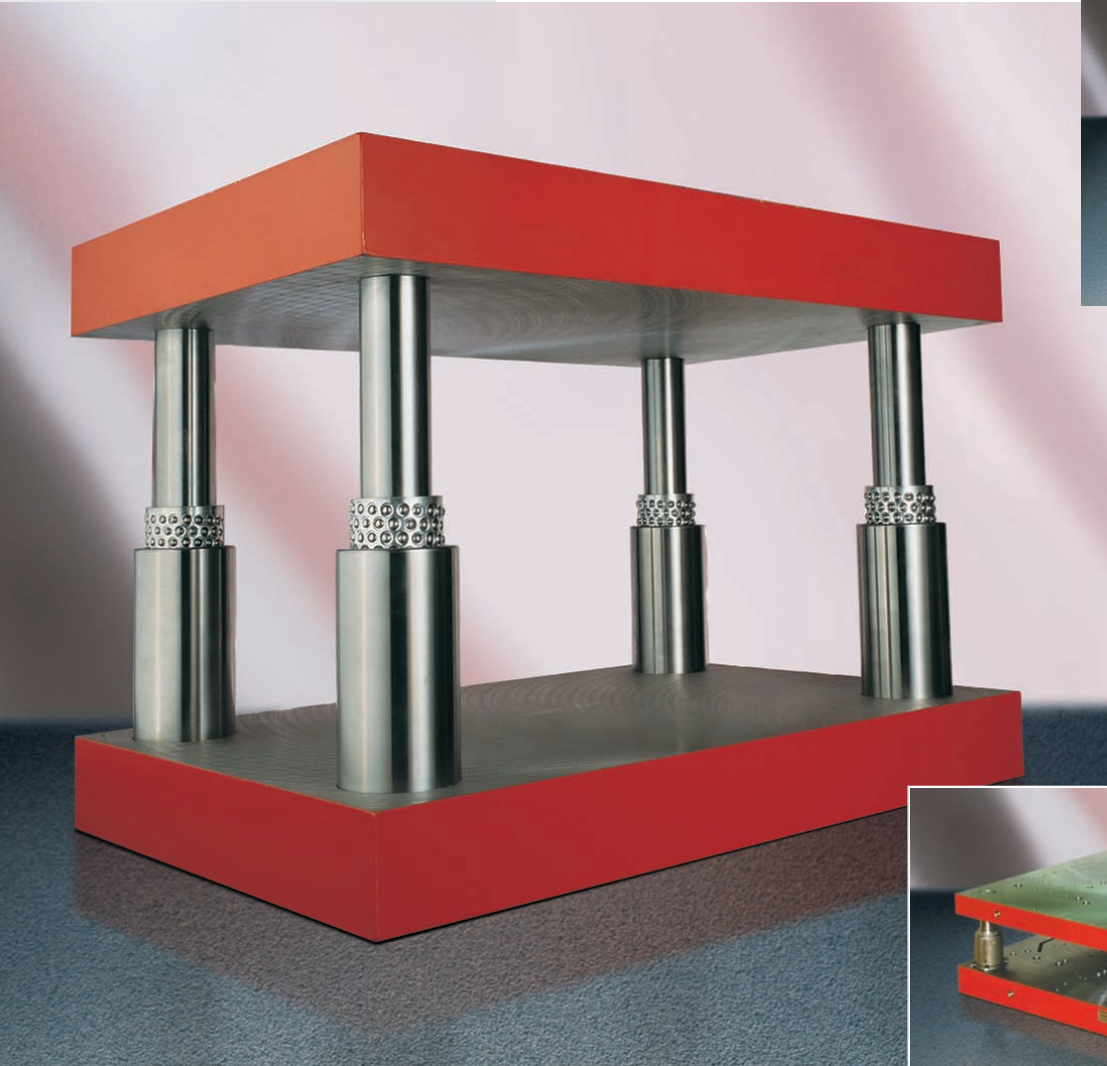
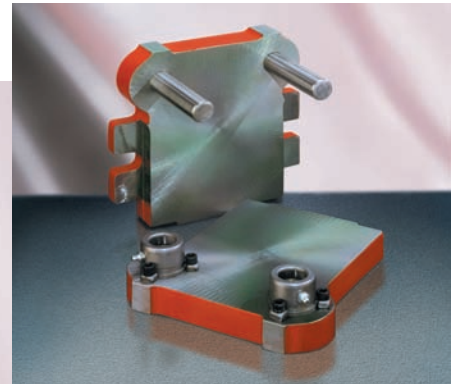
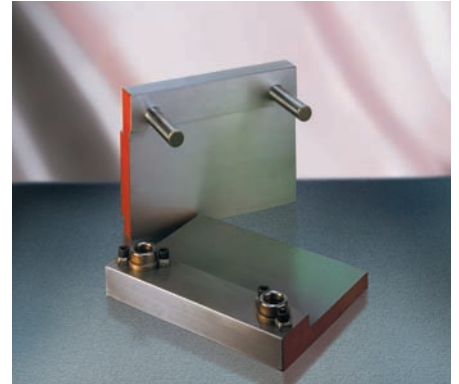

Standard, Two Post Plain Bearing Die Sets

- Standard, in-stock die sets are manufactured with our precision guide pins and standard shoulder bushings.
- Bushing clamp position is for left-to-right feed.
- Please specify pin length (L), quantity needed and catalog number with your order. Unless otherwise specified, standard shoulder length bushings will be supplied.

Order Example

Qty Catalog No. Pin Length
1 2S1006-11 L = 6

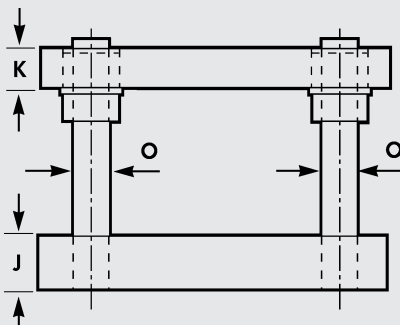

side view

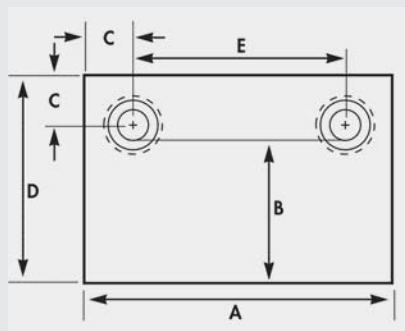

top view

In-stock, 2 Post Plain Bearing Die Sets

Die Space		Thickness		O	D	E	C	Catalog Number
L to R A	F to B B	Die Holder J	Punch Holder K					
6"	4"	1	1	1	6	3	1 1/2	2S64-11
6"	6"	1 1/4	1 1/4	1	8	3	1 1/2	2S66-11
8"	6"	1 1/4	1 1/4	1	8	5	1 1/2	2S86-11
8"	6"	1 1/4	1 1/2	1	8	5	1 1/2	2S86-12
8"	6"	1 1/2	1 1/4	1	8	5	1 1/2	2S86-21
8"	6"	1 1/2	1 1/2	1	8	5	1 1/2	2S86-22
10"	6"	1 1/4	1 1/4	1	8	7	1 1/2	2S1006-11
10"	6"	1 1/4	1 1/2	1	8	7	1 1/2	2S1006-12
10"	6"	1 1/2	1 1/4	1	8	7	1 1/2	2S1006-21
10"	6"	1 1/2	1 1/2	1	8	7	1 1/2	2S1006-22
10"	10"	1 1/2	1 1/2	1 1/4	12 1/4	6 3/4	1 5/8	2S1010-11
10"	10"	1 1/2	2	1 1/4	12 1/4	6 3/4	1 5/8	2S1010-12
10"	10"	2	1 1/2	1 1/4	12 1/4	6 3/4	1 5/8	2S1010-21
10"	10"	2	2	1 1/4	12 1/4	6 3/4	1 5/8	2S1010-22
12"	6"	1 1/2	1 1/2	1 1/4	8 1/4	8 3/4	1 5/8	2S1206-11
12"	6"	1 1/2	2	1 1/4	8 1/4	8 3/4	1 5/8	2S1206-12
12"	6"	2	1 1/2	1 1/4	8 1/4	8 3/4	1 5/8	2S1206-21
12"	6"	2	2	1 1/4	8 1/4	8 3/4	1 5/8	2S1206-22
14"	6"	1 1/2	1 1/2	1 1/2	8 1/2	10 1/2	1 3/4	2S1406-11
14"	6"	1 1/2	2	1 1/2	8 1/2	10 1/2	1 3/4	2S1406-12
14"	6"	2	1 1/2	1 1/2	8 1/2	10 1/2	1 3/4	2S1406-21
14"	6"	2	2	1 1/2	8 1/2	10 1/2	1 3/4	2S1406-22
14"	10"	1 1/2	1 1/2	1 1/2	12 1/2	10 1/2	1 3/4	2S1410-11
14"	10"	1 1/2	2	1 1/2	12 1/2	10 1/2	1 3/4	2S1410-12
14"	10"	2	1 1/2	1 1/2	12 1/2	10 1/2	1 3/4	2S1410-21
14"	10"	2	2	1 1/2	12 1/2	10 1/2	1 3/4	2S1410-22
16"	10"	1 1/2	1 1/2	1 1/2	12 1/2	12 1/2	1 3/4	2S1610-11
16"	10"	1 1/2	2	1 1/2	12 1/2	12 1/2	1 3/4	2S1610-12
16"	10"	2	1 1/2	1 1/2	12 1/2	12 1/2	1 3/4	2S1610-21
16"	10"	2	2	1 1/2	12 1/2	12 1/2	1 3/4	2S1610-22
18"	8"	1 1/2	1 1/2	1 1/2	10 1/2	14 1/2	1 3/4	2S1808-11
18"	8"	1 1/2	2	1 1/2	10 1/2	14 1/2	1 3/4	2S1808-12
18"	8"	2	1 1/2	1 1/2	10 1/2	14 1/2	1 3/4	2S1808-21
18"	8"	2	2	1 1/2	10 1/2	14 1/2	1 3/4	2S1808-22
20"	12"	1 1/2	1 1/2	1 1/2	14 1/2	16 1/2	1 3/4	2S2012-11
20"	12"	1 1/2	2	1 1/2	14 1/2	16 1/2	1 3/4	2S2012-12
20"	12"	2	1 1/2	1 1/2	14 1/2	16 1/2	1 3/4	2S2012-21
20"	12"	2	2	1 1/2	14 1/2	16 1/2	1 3/4	2S2012-22

Custom, Two Post All Steel Die Sets

Back Post - Type 2B

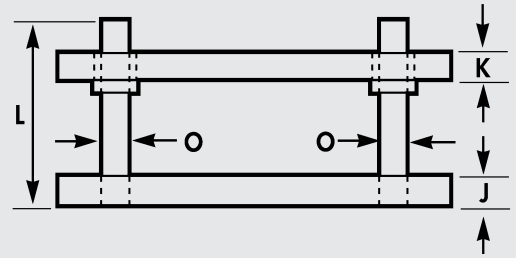
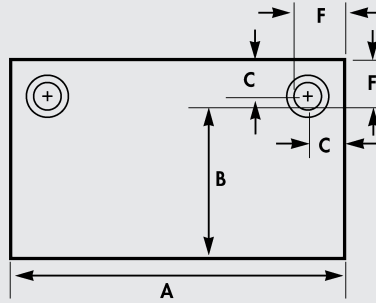

Diagonal Post - Type 2D

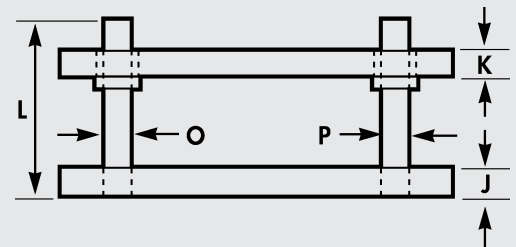
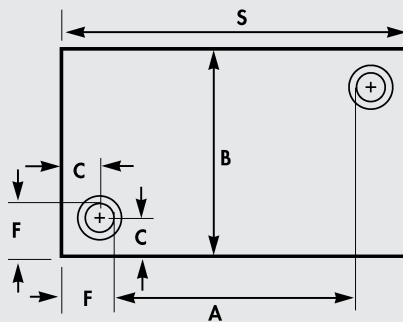
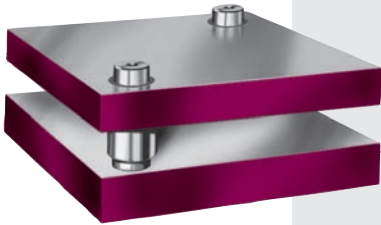

Can be made with posts on other diagonal, if specified.
Center of die space is in the center of the die plates.

Center Post - Type 2C

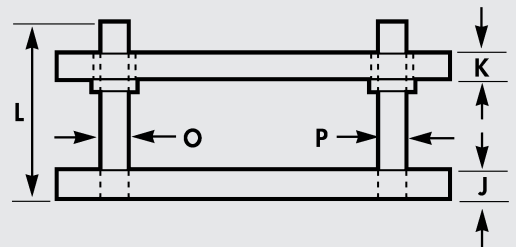
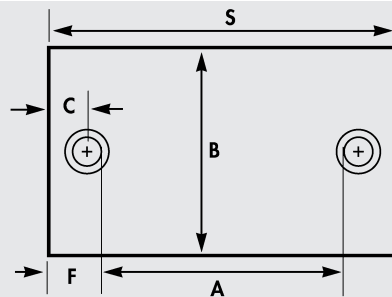

Center of die space is in the center of the die plates.

When ordering custom, all steel die sets, specify:

1. Type 2B, 2D, or 2C. Note: O & P should be different diameters on Type 2D & 2C die sets.
2. Dimensions A, B, J, K, and L.
3. Type bushings - sintered bronze bushings supplied unless otherwise specified.
4. Diameter of threaded shank, if wanted. See page 9 for Threaded Shank Selection Chart.
5. How shipment should be made.
6. Custom die sets may not be returned for credit.
7. Quantity needed.

Two Post Die Sets

Dimensions furnished when customer specifies only A and B dimensions. B dimension does not affect table.

Die Space L to R A	Post Diameter O	Post Diameter P	D.H. Thickness J	P.H. Thickness K	F for O Post	C for O Post	C for P Post	S
6" to 8"	1	--	1 1/4	1 1/4	2	1 1/2	--	--
9" to 12"	1 1/4	1	1 1/2	1 1/2	2 1/4	1 5/8	1 3/4	A + 4 1/2
13" to 16"	1 1/2	1 1/4	1 1/2	1 1/2	2 1/2	1 3/4	1 7/8	A + 5
17" to 22"	1 3/4	1 1/2	1 3/4	1 3/4	2 3/4	1 7/8	2	A + 5 1/2
23" to 28"	2	1 3/4	2	2	3	2	2 1/8	A + 6
29" to 40"	2	1 3/4	2 1/2	2 1/2	3	2	2 1/8	A + 6
41" to 65"	2 1/2	2	3	3	3 3/4	2 1/2	2 3/4	A + 7 1/2

Custom, Four Post All Steel Die Sets

Four Post - Type 4P

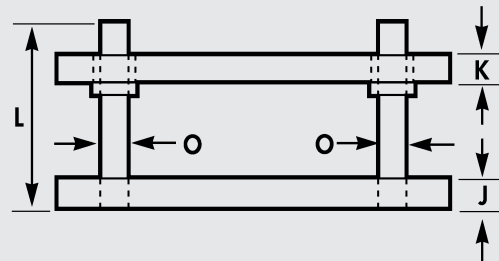
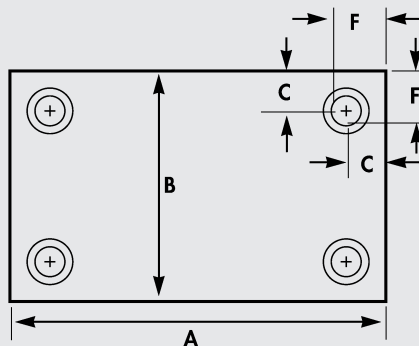
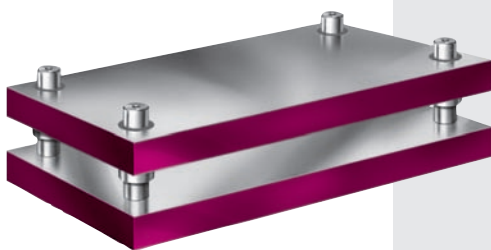

Right front pin offset 1/8".

When ordering custom, all steel die sets, specify:

1. This table shows accepted design dimensions. Any or all of these dimensions, however, can be changed to conform to customer's specifications of A, B, O, P, J, K, L, F or W, etc.
2. All die sets are always made so that the punch holder can not be reversed on die holder. Type 4Ps are made with same diameter posts, but the right front post is offset 1/8" toward outside edge of die set.
3. Any of these sets are available both with or without shank. Unless otherwise specified, shank is always located in middle of both A and B dimensions. For safety reasons, we supply only threaded shanks. See page 9 for Threaded Shank Selection Chart.
4. Die sets of design other than shown in catalog can be furnished in steel or aluminum.
5. Custom die sets may not be returned for credit.
6. Sintered Bronze Bushings supplied unless otherwise specified.

Four Post Die Sets

Dimensions furnished when customer specifies only A and B dimensions.

Die Space L to R A	Post Diameter O	D.H. Thickness J	P.H. Thickness K
6" to 10"	1	1 1/4	1 1/4
11" to 16"	1 1/4	1 1/2	1 1/2
17" to 22"	1 1/2	1 3/4	1 3/4
23" to 28"	1 3/4	2	2
29" to 40"	2	2 1/2	2 1/2
41" to 65"	2 1/2	3	3

These dimensions apply to both two post and four post sets.

Nominal Guide Post Diameter	C	F
3/4"	1 1/4	1 5/8
1"	1 1/2	2
1 1/4"	1 5/8	2 1/4
1 1/2"	1 3/4	2 1/2
1 3/4"	1 7/8	2 3/4
2"	2	3
2 1/2"	2 1/2	3 3/4
3"	2 3/4	4 1/4

Let Us Quote Your Special Applications

- Aluminum die sets.
- Three and four platen die sets.
- Plate work, ground or unground.
- Stress relieved plates.
- Die sets can be made with heel blocks.
- Per print CNC machining, holes, keyways, cutouts and burnouts.

Custom, Two Post Ball Bearing Die Sets

Back Post - Type 2BB

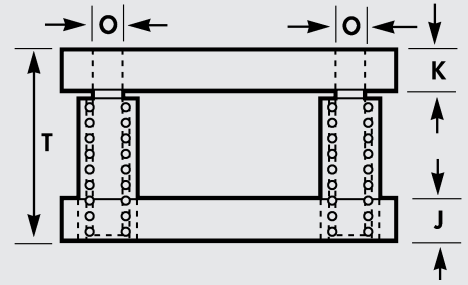
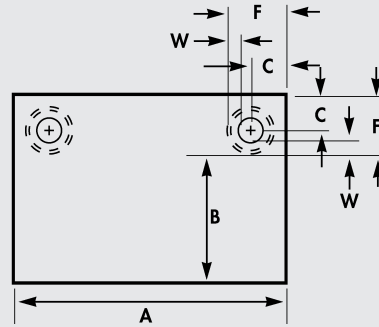

Diagonal Post - Type 2BD

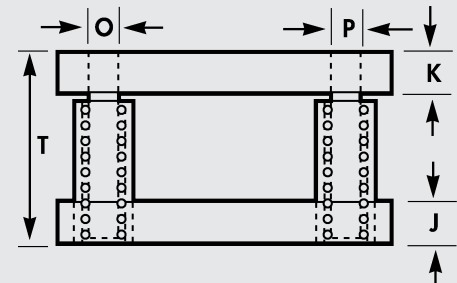
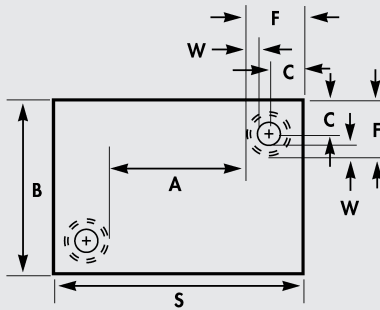
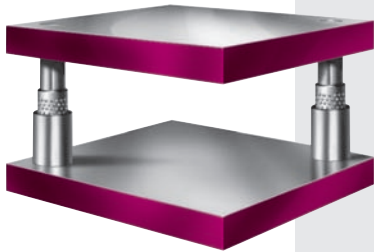

Center of die space is in the center of the die plates.

Center Post - Type 2BC

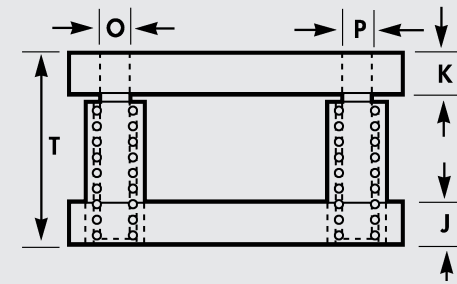
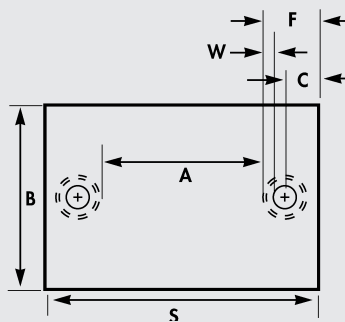

Center of die space is in the center of the die plates.

When ordering custom ball bearing die sets, specify:

1. Type 2BB, 2BD, or 2BC.
2. Dimensions A, B, J, and K.
3. Ball bearing die sets will be furnished with straight steel sleeve bushings or demountable ball bearing bushings.
4. Dimension "T" is minimum shut height.
5. Post diameter "O" & "P". (O and P should be different for 2BD and 2BC.)
6. Custom die sets may not be returned for credit.
7. Quantity needed.

Two Post Die Sets Dimensions furnished when customer specifies only A and B dimensions.

Die Space L to R A	Post Diameter O	Post Diameter P	D.H. Thickness J	P.H. Thickness K	F for Sleeve Bushing	F for Demountable Bushing	C For O Post	C for P Post (Sleeve Bushing)	C for P Post (Demountable Bushing)	S
6" to 8"	1	--	1 1/4	1 1/4	2 11/16	2 7/8	1 3/4	--	--	--
9" to 12"	1 1/4	1	1 1/2	1 1/2	2 15/16	3 1/16	1 7/8	2	2	A + 2F
13" to 16"	1 1/2	1 1/4	1 1/2	1 1/2	3 3/8	3 9/16	2 1/8	2 1/4	2 3/8	A + 2F
17" to 22"	1 3/4	1 1/2	1 3/4	1 3/4	3 5/8	3 13/16	2 1/4	2 3/8	2 3/8	A + 2F
23" to 28"	2	1 3/4	2	2	4 1/8	4 5/16	2 1/2	2 3/4	2 3/4	A + 2F
29" to 40"	2	1 3/4	2 1/2	2 1/2	4 1/8	4 5/16	2 1/2	2 3/4	2 3/4	A + 2F
41" to 65"	2 1/2	2	3	3	4 3/4	5	2 7/8	3 1/8	3 1/8	A + 2F

Custom, Four Post Ball Bearing Die Sets

Four Post - Type 4BB

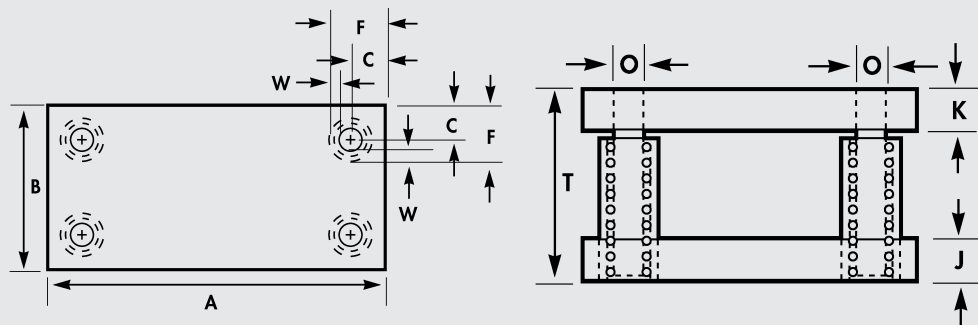

Right front pin offset 1/4" to outside.

Ball Bearing Component Selection

Refer to pages 18 and 19 of the Selective Fit Pin and Bushing Guiding catalog for the correct selection of operating condition and components. Please note that on long stroke applications, the pin and cage can be disengaged **only** if the press is operated at less than 150 spm and in a vertical position with accurate ram gib alignment.

Maximum Pin Length

= Minimum Shut Height - 3/4"

Maximum Straight Sleeve Length

= Minimum Shut Height - Punch Holder Thickness - 1/4"

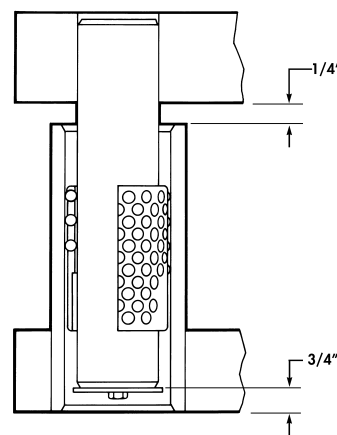

Tool at Minimum Shut Height (die life depleted)

Four Post Die Sets

Dimensions furnished when customer specifies only A and B dimensions.

Die Space L to R A	Post Diameter O	D.H. Thickness J	P.H. Thickness K
8" to 10"	1	1 1/4	1 1/4
11" to 16"	1 1/4	1 1/2	1 1/2
17" to 22"	1 1/2	1 3/4	1 3/4
23" to 28"	1 3/4	2	2
29" to 40"	2	2 1/2	2 1/2
41" to 65"	2 1/2	3	3

These dimensions apply to both two post and four post sets.

Nominal Guide Post Diameter	C	Sleeve Bushing		Demountable Bushings	
		F	W	F	W
1"	1 3/4	2 11/16	7/16	2 7/8	9/16
1 1/4"	1 7/8	2 15/16	7/16	3 1/16	9/16
1 1/2"	2 1/8	3 3/8	1/2	3 9/16	11/16
1 3/4"	2 1/4	3 5/8	1/2	3 13/16	11/16
2"	2 1/2	4 1/8	5/8	4 5/16	13/16
2 1/2"	2 7/8	4 3/4	5/8	5	13/16
3"	3 1/4	--	--	5 5/8	7/8

Ground Plate Specifications

- **AISI 1020 Mild Steel Plate** - 21 sizes in stock, from 1/2" to 4".
- **Blanchard Grinding Available** - call for details.
- **Also available in aluminum** - not stocked, specify grade.
- **Send us your prints** - Our email is: STDDIE@readytechnology.com

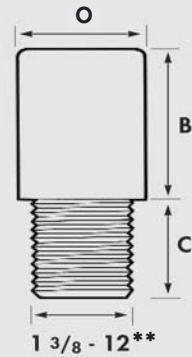

**PS-O 5/8 - 11 only

Threaded Shank Selection

Diameter O	Length B	Length Thread C	Catalog Number
1"	13/4"	1 3/4	PS-0
1 1/2"	2"	1	PS-1
		1 1/4	PS-2
		1 3/8	PS-3
		1 1/2	PS-4
		1 5/8*	PS-5
		1 3/4	PS-6
		2*	PS-7
		2 1/4	PS-8
		2 1/2*	PS-9
1 9/16"	2"	1	PS-11
		1 1/4	PS-12
		1 3/8	PS-13
		1 1/2	PS-14
		1 5/8*	PS-15
		1 3/4	PS-16
		2*	PS-17
		2 1/4	PS-18
		2 1/2*	PS-19
2"	2 3/4"	1 1/4	PS-21
		1 3/8	PS-22
		1 1/2	PS-23
		1 5/8*	PS-24
		1 3/4	PS-25
		2*	PS-26
		2 1/4	PS-27
		2 1/2*	PS-28
2 1/2"	2 3/4"	1 1/4	PS-31
		1 3/8	PS-32
		1 1/2	PS-33
		1 5/8*	PS-34
		1 3/4	PS-35
		2*	PS-36
2 1/4	PS-37		
2 1/2*	PS-38		
3"	2 3/4"	1 1/4	PS-41
		1 3/8	PS-42
		1 1/2	PS-43
		1 5/8*	PS-44
		1 3/4	PS-45
		2*	PS-46
		2 1/4	PS-47
2 1/2*	PS-48		

Pertinent Die Set Standards

Flatness Plates	.0005 per lineal foot
Parallelism Plates	.001 per lineal foot
Thickness Plates	±1/16 stock sets
Thickness Plates	+ 1/16 -1/8 special sets
Shank Diameter	+ .000 -.002
Guide Pins Squareness	.001 in 6 inches
Guide Pins Parallelism	.001 in 6 inches
Guide Bushings Squareness	.001 in 6 inches
Guide Bushings Parallelism	.001 in 6 inches
Parallelism Assembled Die Set	.0015 per lineal foot

Blanchard Ground Stripper Plates

- Burned edges
- Thickness +1/16 / - 0
- AISI 1020 steel available from stock

Overall Size	Thickness	Overall Size	Thickness
SP - 6" x 18"	1/2	SP - 18" x 18"	1/2
	3/4		3/4
	1		1
	1 1/4		1 1/4
SP - 10" x 18"	1 1/2	SP - 12" x 24"	1/2
	1		3/4
	1 1/4		1
	1 1/2		1
SP - 14" x 18"	1/2	SP - 24" x 25"	1/2
	3/4		3/4
	1		1
	1 1/4		1

* stock lengths

Aluminum Die Sets, Plates, Ram and Mold Plates

Advantages of Aluminum:

- One-third the weight of steel
- Faster and easier setup
- Less wear and tear on the machine (clutch, brake, ram, ...)
- Easy machinability means 20-35% increased feed rates
- Uses existing conventional cuttings tools
- Draws heat away from tooling, then dissipates heat quickly
- Rust free, least susceptible to elements
- Impervious to typical (water soluble) die lubes
- Non-magnetic - good environment for in-die sensing
- Stress relieved in the process - a stable material before/after machining
- Easily recyclable

Note: It is recommended to finish heavy (point pressures) machining before grinding for best results. We do not recommend using steel and aluminum plates in a die set combination.

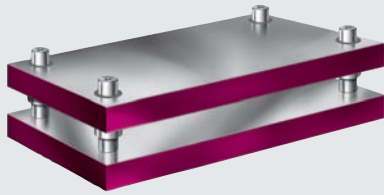

Four Post - Type 4P



Back Post - Type 2B

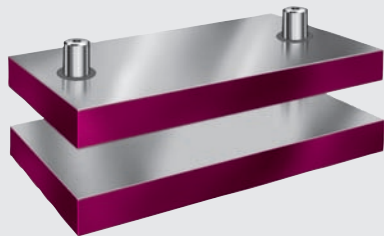

Center Post - Type 2C

Comparative Technical Data	Physical & Mechanical Properties	Tensile Strength (psi)	Yield Strength (psi)	Density (lb/inch ³)	Thermal Conductivity*	Thermal Expansion**	Modulus of Elasticity***	Typical Hardness (Rc equivalent)
Hot Rolled Steel	1020	64,000	50,000	.283	20.0	6.3	30	135B (12Rc)
Aircraft Aluminum	6013	58,000	54,000	.098	95	13.0	10.1	120B (11Rc)
Aircraft Aluminum	6061	46,000	42,000	.098	96	13.1	10.0	95B (8Rc)
Aircraft Aluminum	7075	75,000	73,000	.101	75	13.1	10.4	150B (14Rc)
Aircraft Aluminum	QC7	79,000	64,000	.102	91	12.8	10.3	167B (17Rc)
Alloy Steel	4140	102,000	90,000	.282	24.7	6.2	30	220B (21Rc)

* (btu/ft/hr/ft²/°F)

** average coefficient (x 10⁻⁶/in./°F)

*** (x 10⁶ lbs./in.²)